

SEIKO

QUARTZ

Cal. H357A

PARTS LIST

Cal. H357A

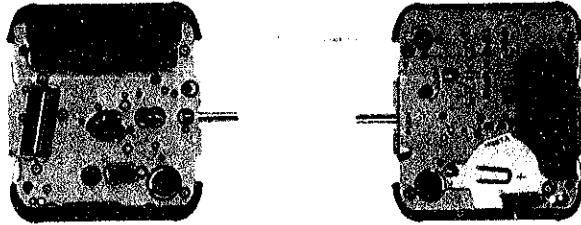

122 651



125 650



☆ 221 650



231 650



☆ 241 650



261 650



☆ 271 650



281 650



282 650



354 650



383 650



384 650



386 650



389 650



391 650



491 546



701 650



766 650

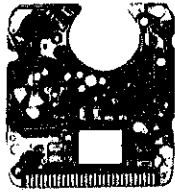

4001 595



4002 650



4146 650



4216 650



4225 650



4239 650



4245 650



4245 651



4246 650



4270 650



4313 650



4398 650

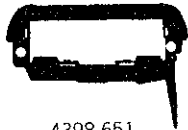

4398 651



4450 650



4408 651



4408 653



☆ 4510 520



4521 790



☆ Maxell SR926W

022 241

022 493

2/1

Cal. H357A

Characteristics

Casing diameter : 23.6 × 26 mm
 Maximum height : 3.3 mm without battery
 Jewel : 7 j
 Frequency of quartz crystal oscillator : 32,768 Hz (Hz=Hertz Cycles per second)
 Analogue indication : Three hand time indication (Hour, Minute and Second)
 Digital time and calendar display : Hour (24 hour indication or 12 hour indication), Minute, Second, Date and Day of the week.
 (The month is displayed only when the calendar is adjusted.)
 Alarm display : Can be set to operate at any desired hour and minute.
 Stop watch display : Digital Display System showing 12 hour, minute, second and 1/100 second up to 60 minutes.
 Display medium : Nematic Liquid Crystal, FE-Mode
 Driving system : Step motor (2 poles)
 Regulation system : Trimmer condenser
 Time signal : It can be set to ring every hour on the hour.
 Battery life indicator : All the digits in the display begin flashing.

| PART NO. | PART NAME | PART NO. | PART NAME |
|-----------|---------------------------------|----------------|---|
| 122 651 | Center wheel bridge | 011 503 | Upper hole jewel for fourth wheel |
| 125 650 | Train wheel bridge | 011 547 | Upper hole jewel for third wheel |
| ☆221 650 | Center wheel & pinion | 011 547 | Upper hole jewel for fifth wheel |
| ☆221 651 | | 011 547 | Lower hole jewel for fifth wheel |
| 231 650 | Third wheel & pinion | 011 550 | Lower hole jewel for third wheel |
| ☆241 650 | Fourth wheel & pinion | 011 552 | Upper hole jewel for step rotor |
| ☆241 651 | | 011 552 | Lower hole jewel for step rotor |
| 261 650 | Minute wheel | 023 330 | Train wheel setting lever adjusting pin |
| ☆271 650 | Hour wheel | 023 347 | Guide pin for setting lever spring A |
| ☆271 651 | | 023 363 | Guide pin for setting lever axle spring |
| 281 650 | Setting wheel | 023 378 | Guide pin for switch spring |
| 282 650 | Clutch wheel | 023 378 | Tube for yoke |
| 354 650 | Winding stem | 027 044 | Tube for coil block screw A |
| 383 650 | Setting lever | 027 067 | Tube for train wheel bridge |
| 384 650 | Yoke (Clutch lever) | 027 068 | Tube for circuit block screw A |
| 386 650 | Setting lever spring | 027 068 | Tube for battery clamp screw A |
| 389 650 | Setting lever axle spring | 027 069 | Tube for circuit block screw B |
| 391 650 | Train wheel setting lever | 027 069 | Tube for battery clamp screw B |
| 491 546 | Dial wheel | 027 075 | Tube for coil block screw B |
| 701 650 | Fifth wheel & pinion | 027 700 | Switch spring fixing pin |
| 766 650 | Intermediate minute wheel | 027 701 | Guide pin for setting lever spring B |
| 4001 595 | Circuit block | 027 898 | Setting lever pin |
| 4002 650 | Coil block | 027 946 | Eccentric dial pin |
| 4146 650 | Step rotor | ☆Maxell SR926W | Silver oxide battery |
| 4216 650 | Insulator for battery | ☆U.C.C. 399 | |
| 4225 650 | Battery clamp | ☆SEIKO TR926W | Silver (II) oxide battery |
| 4239 650 | Rotor stator | | |
| 4245 650 | Switch spring | | |
| 4245 651 | Changeover switch spring | | |
| 4246 650 | Buzzer lead terminal | | |
| 4270 650 | Battery connection (-) | | |
| 4313 650 | Connector | | |
| 4398 650 | Battery guard | | |
| 4398 651 | Liquid crystal panel frame | | |
| 4450 650 | Switch lever | | |
| 4408 651 | Reflecting mirror spacer | | |
| 4408 653 | Washer for circuit block screw | | |
| ☆4510 520 | Liquid crystal panel (Silver) | | |
| ☆4510 521 | Liquid crystal panel (Gold) | | |
| 4521 790 | Reflecting mirror | | |
| 022 241 | Center wheel bridge screw | | |
| 022 241 | Train wheel bridge screw | | |
| 022 241 | Coil block screw | | |
| 022 241 | Setting lever spring screw | | |
| 022 241 | Setting lever axle spring screw | | |
| 022 493 | Circuit block screw | | |
| 022 493 | Battery clamp screw | | |

☆⇨ Please see remarks on the reverse page.
 Part numbers in light letters are not shown in photos.





Cal. H357A

Remarks :

Center wheel & pinion, Fourth wheel & pinion, Hour wheel

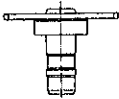
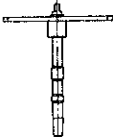
There are two different types as specified below.

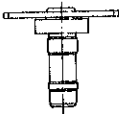
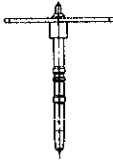
Combination :

| Type | Center wheel & pinion | Fourth wheel & pinion | Hour wheel |
|--|---|---|---|
| a. Dials for thin type models. (Standard type) |  ☆221 650 |  ☆241 650 |  ☆271 650 |
| b. Dials for thick type models (Two-layer type) |  ☆221 651 |  ☆241 651 |  ☆271 651 |

Liquid crystal panel

☆4510 520 (Silver) } Be sure that the combination between the color of panel cover and liquid crystal
 ☆4510 521 (Gold) } panel should be matched according to the "SEIKO Quartz Casing Parts List".

Battery

☆SEIKO TR926W } The substitutive battery might be added to the applied battery in the future.
 ☆Maxell SR926W } In that case, please refer to separate "BATTERY LIST FOR SEIKO QUARTZ
 ☆U.C.C. 399 } WATCHES".
 Note that SEIKO battery is marked with "SEIZAIKEN" on its (+) side.

TECHNICAL GUIDE

SEIKO
QUARTZ.

CONTENTS

| | |
|---|----|
| I. SPECIFICATIONS | 1 |
| II. STRUCTURE OF THE CIRCUIT BLOCK | 1 |
| III. DISPLAY FUNCTION | 2 |
| IV. DISASSEMBLING, REASSEMBLING AND LUBRICATING | 3 |
| 1. Disassembling, reassembling and lubricating of the case | 3 |
| 2. Disassembling, reassembling and lubricating of the movement (module) | 4 |
| 3. Relationship between the segment (Liquid Crystal Panel Electrode) and the C-MOS-LSI output terminal | 11 |
| V. CHECKING AND ADJUSTMENT | 12 |
| • Check battery voltage | 12 |
| • Check battery conductivity | 12 |
| • Check current consumption | 12 |
| • Check water resistance | 13 |

I. SPECIFICATIONS

| Item | Cal. No. | H357A |
|-------------------|-------------------------------|--|
| Analogue function | Time indication | Three-hand time indication (Hour, minute and second) |
| | Additional mechanism | <ul style="list-style-type: none"> • Electronic circuit reset switch • Train wheel setting (stops at every second) |
| Digital function | Display medium | Nematic Liquid Crystal, FEM (Field Effect Mode) |
| | Display system | <ul style="list-style-type: none"> • Calendar function • Time function (12 or 24 hour indication) • Alarm function (12 or 24 hour indication) • Stopwatch function |
| | Additional mechanism | <ul style="list-style-type: none"> • Battery life indicator • Alarm test system • Time signal • Pattern segment checking system |
| | Liquid crystal driving system | 1/2 Multiplex driving system |
| Loss/gain | | Loss/gain at normal temperature range Monthly rate: less than 10 seconds (Annual rate: less than 2 minutes) |
| Movement size | | 23.6mm (between 3 o'clock and 9 o'clock sides) 26.0mm (between 6 o'clock and 12 o'clock sides) |
| Height | | 3.3mm without battery |
| Regulation system | | Trimmer condenser |
| Measuring gate | | Any gate is available. |
| Battery | | SEIKO TR926W, Maxell SR926W or U.C.C. 399 Battery life is approximately 2 years. Voltage: 1.55V |
| Jewels | | 7 jewels |

II. STRUCTURE OF CIRCUIT BLOCK

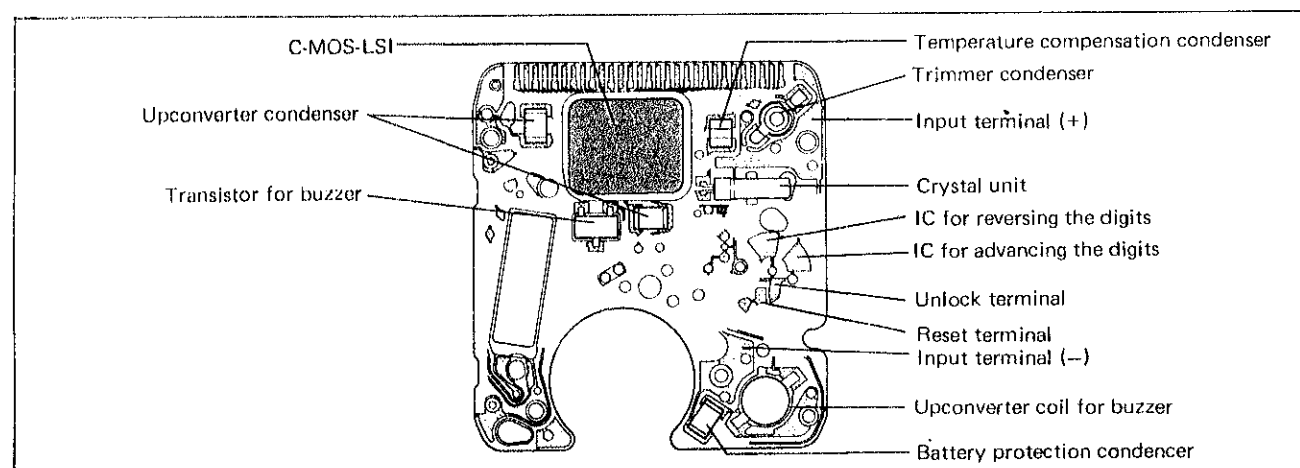

III. DISPLAY FUNCTION (Digital function)

• **Calendar display**

Alarm set mark

Day Date

* Alarm set mark is displayed when the alarm function is activated.

• **Time display**

12-hour indication

24-hour indication

Alarm set mark

AM/PM Hour Minute Second

• **Alarm time display**

12-hour indication

24-hour indication

Alarm set mark

Alarm function mark AM/PM Hour Minute

• **Stopwatch display**

Alarm set mark

Minute Second 1/100 second

IV. DISASSEMBLING, REASSEMBLING AND LUBRICATING

1. Disassembling, reassembling and lubricating of the case

- Lubricating

| | |
|------------------------------|-----------------|
| Type of oil | Oil quantity |
| Moebius A | Normal quantity |
| SEIKO Watch Oil S-6 | Small quantity |
| Silicone grease 500,000 c.s. | |

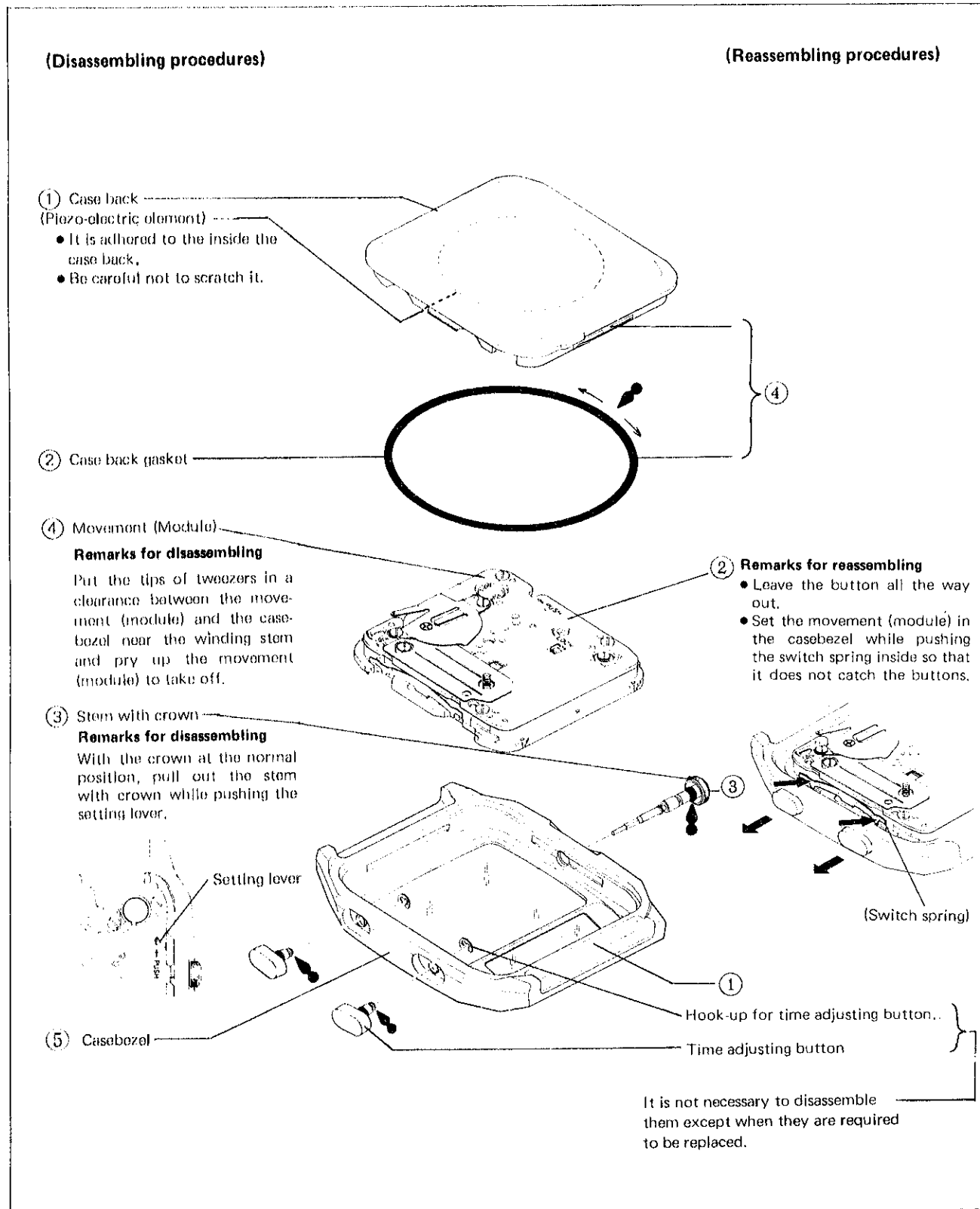

2. Disassembling, reassembling and lubricating of the movement (module)

Disassembling procedures Figs.: ① ~ ④⑤

Reassembling procedures Figs.: ④⑤ ~ ①

• List of screws used

| Shape | Parts No. | Parts Name | Shape | Parts No. | Parts Name |
|-------|-----------|---|-------|-----------|------------------------------|
| | 022 241 | Center wheel bridge screw (1 pc.) | | 022 493 | Circuit block screw (4 pcs.) |
| | | Train wheel bridge screw (3 pcs.) | | | Battery clamp screw (2 pcs.) |
| | | Coil block screw (1 pc.) | | | |
| | | Setting lever spring screw (2 pcs.) | | | |
| | | Setting lever axle spring screw (1 pc.) | | | |

- Use the movement (module) holder S-672 for disassembling and reassembling.

(1) Disassembling and reassembling of ① Hour, minute and second hands ~ ④ Hour wheel

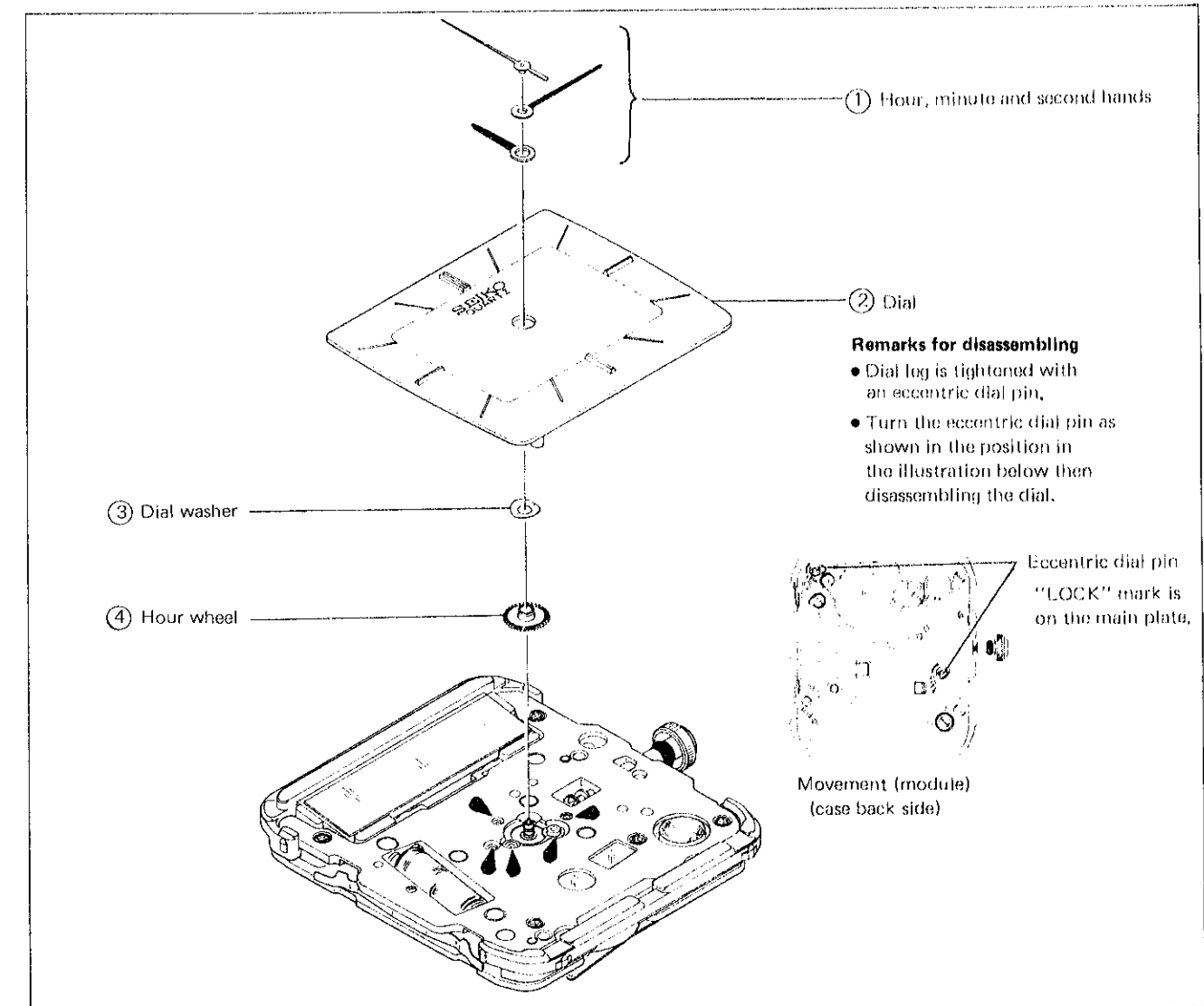

(2) Disassembling and reassembling of ⑤ Battery clamp screw ~ ⑱ Insulator for battery

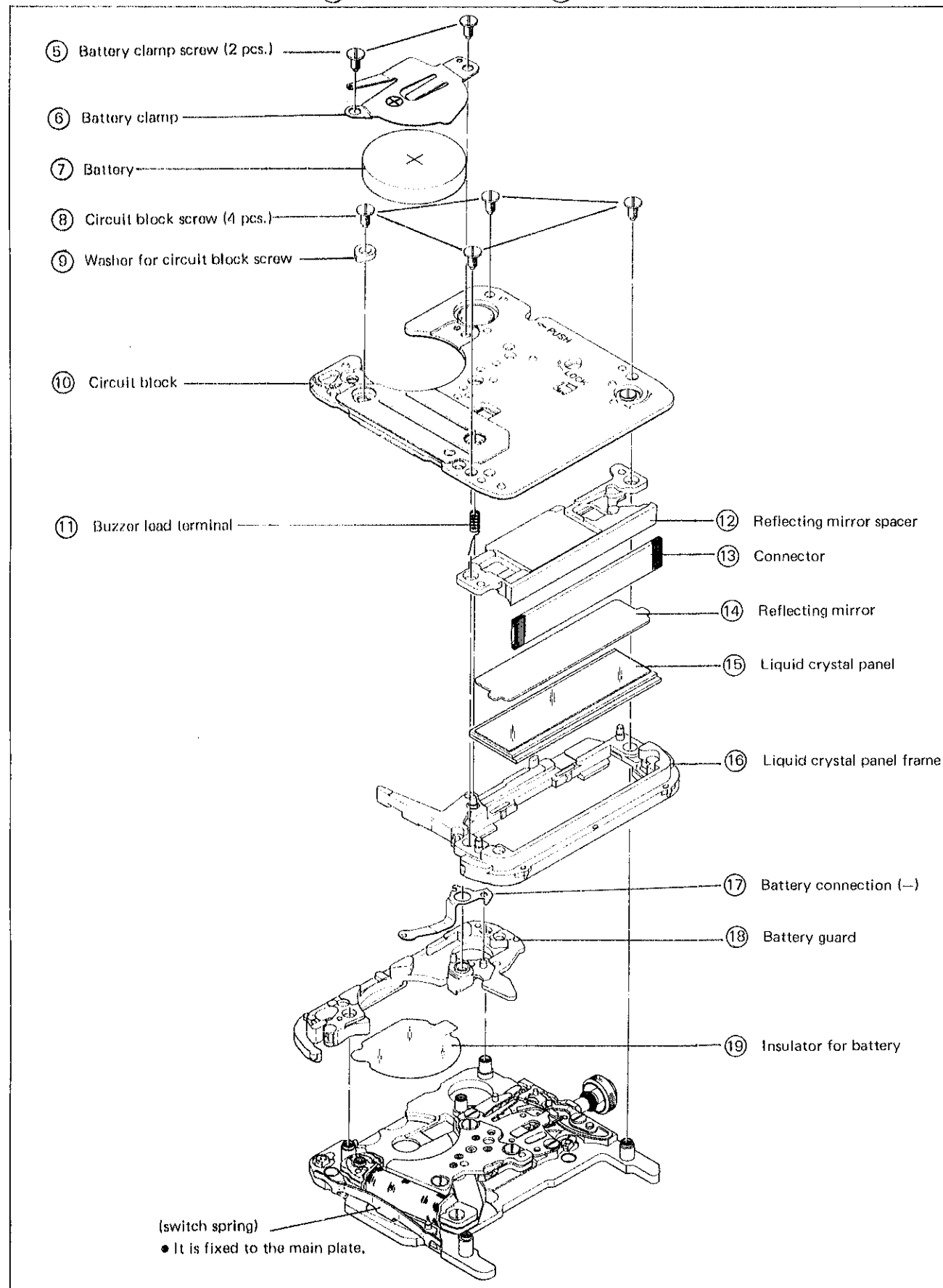

Remarks for disassembling and reassembling

⑩ Circuit block

- Be careful not to touch the elements except when it is required.

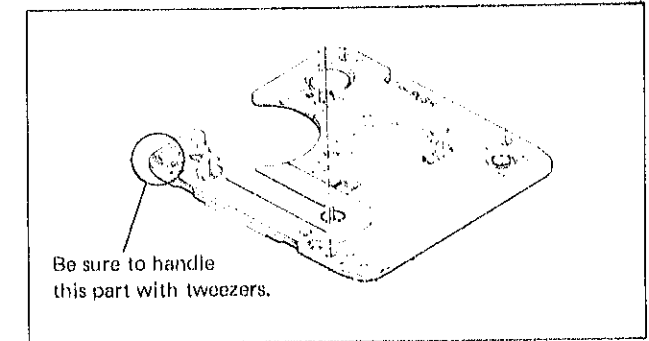

Remarks for reassembling

⑪ Buzzer lead terminal

- Set the buzzer lead terminal on the pin of the liquid crystal panel frame.
- Be sure to set it vertically.
- Set the tip of the buzzer lead terminal in the groove for positioning on the liquid crystal panel frame as shown in the illustration on the right.

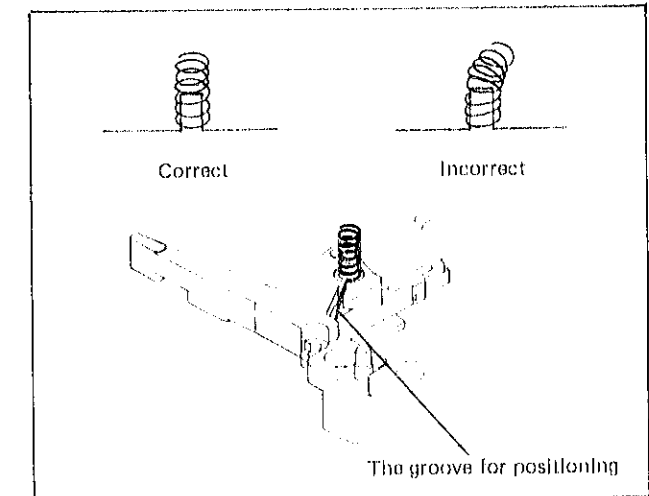

⑮ Liquid crystal panel

- The electrode turns upward at the 12 o'clock direction.
- Be careful not to mistake the top for bottom.

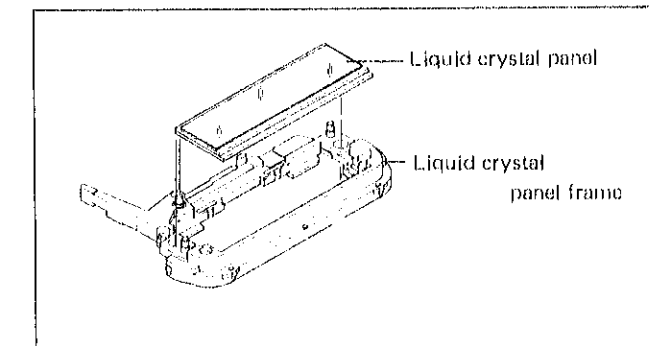

⑱ Battery guard

- Set the battery guard so that it does not catch the switch spring.

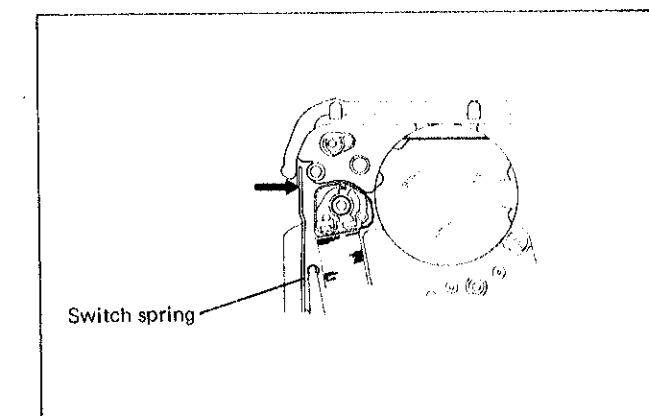

(3) Disassembling and reassembling of ⑳ Coil block screw ~ ㉑ Train wheel setting lever

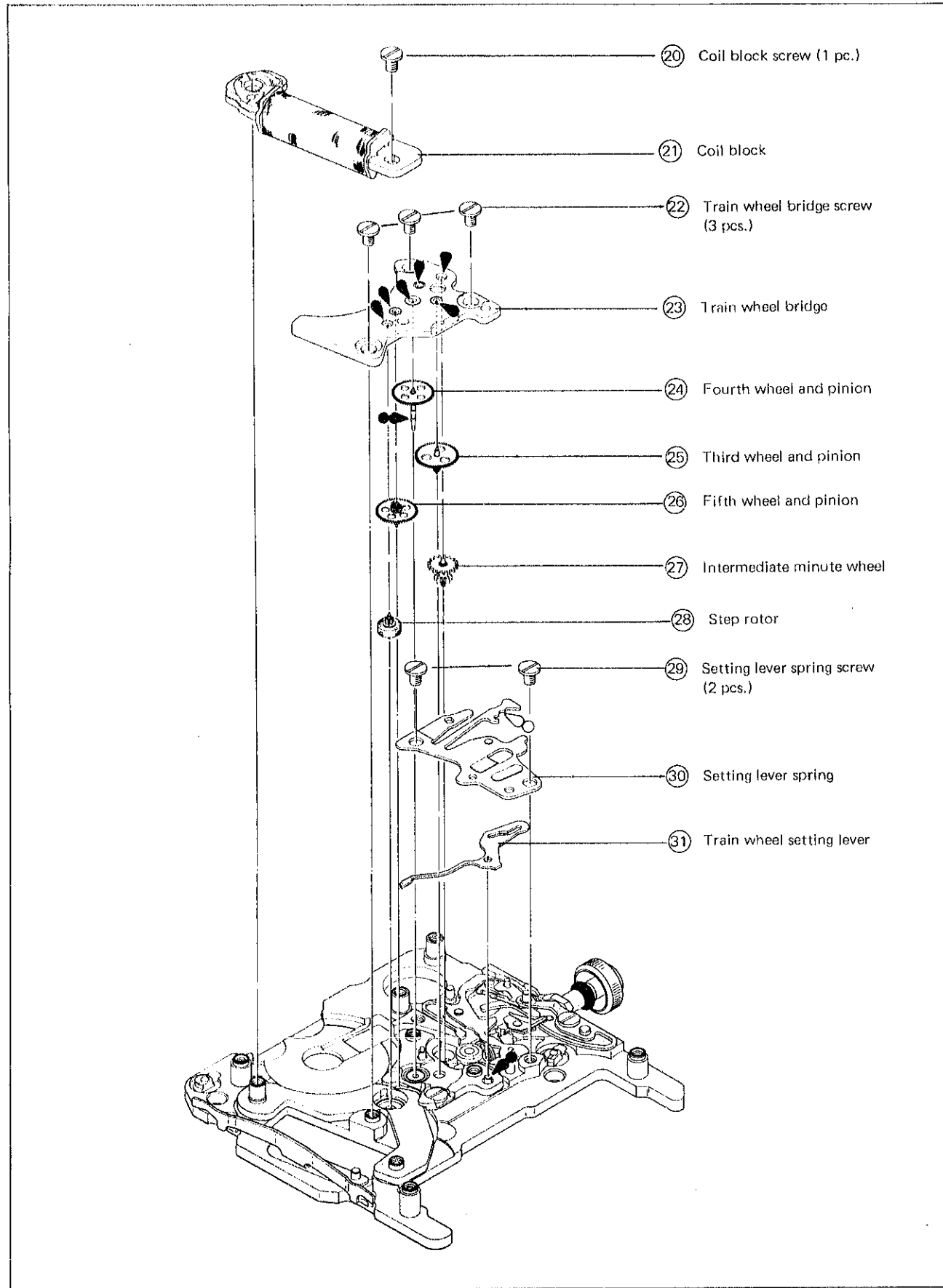

Remarks for reassembling

㉘ Step rotor

- Use a microscope to check the clearances from the arrow marked direction.

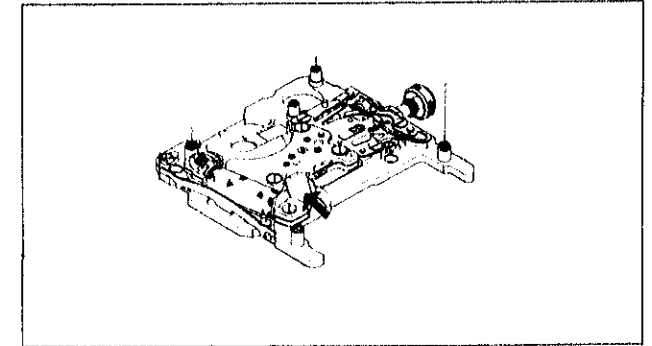

- Check the clearances for the upper and lower pivots for the step rotor after tightening the coil block screw.
- Check the clearance for the lower pivot by depressing the upper pivot by tweezers or a probe.
- Check the clearances by using the diameter of the pivot as a guide.

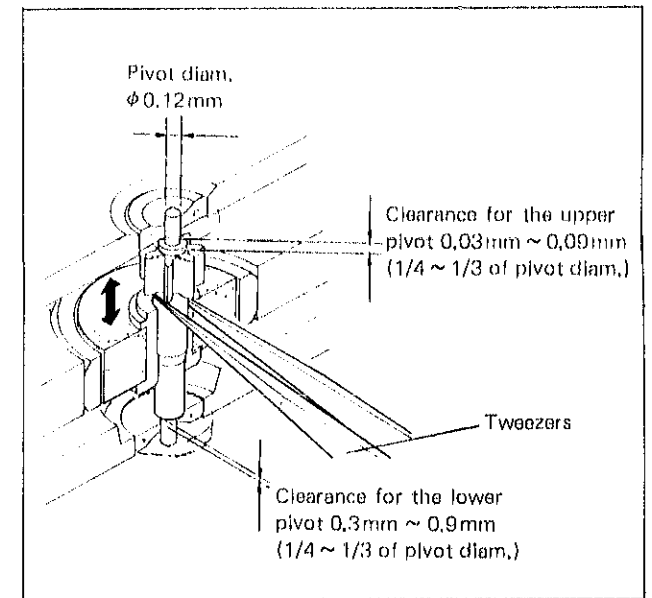

㉛ Train wheel setting lever

- Place the elongate hole on the pin portion of the yoke to set the train wheel setting lever as shown in the illustration on the right.

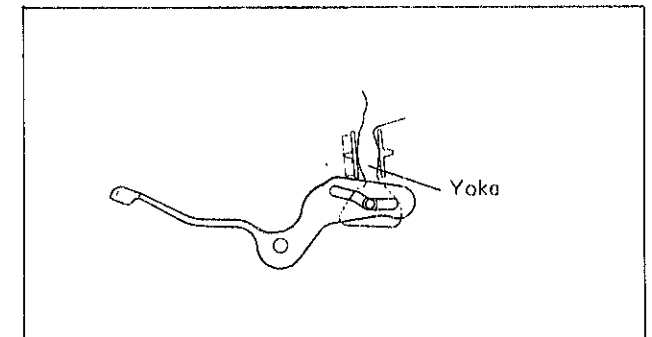

(4) Disassembling and reassembling of ③② Setting wheel~④⑤ Rotor stator

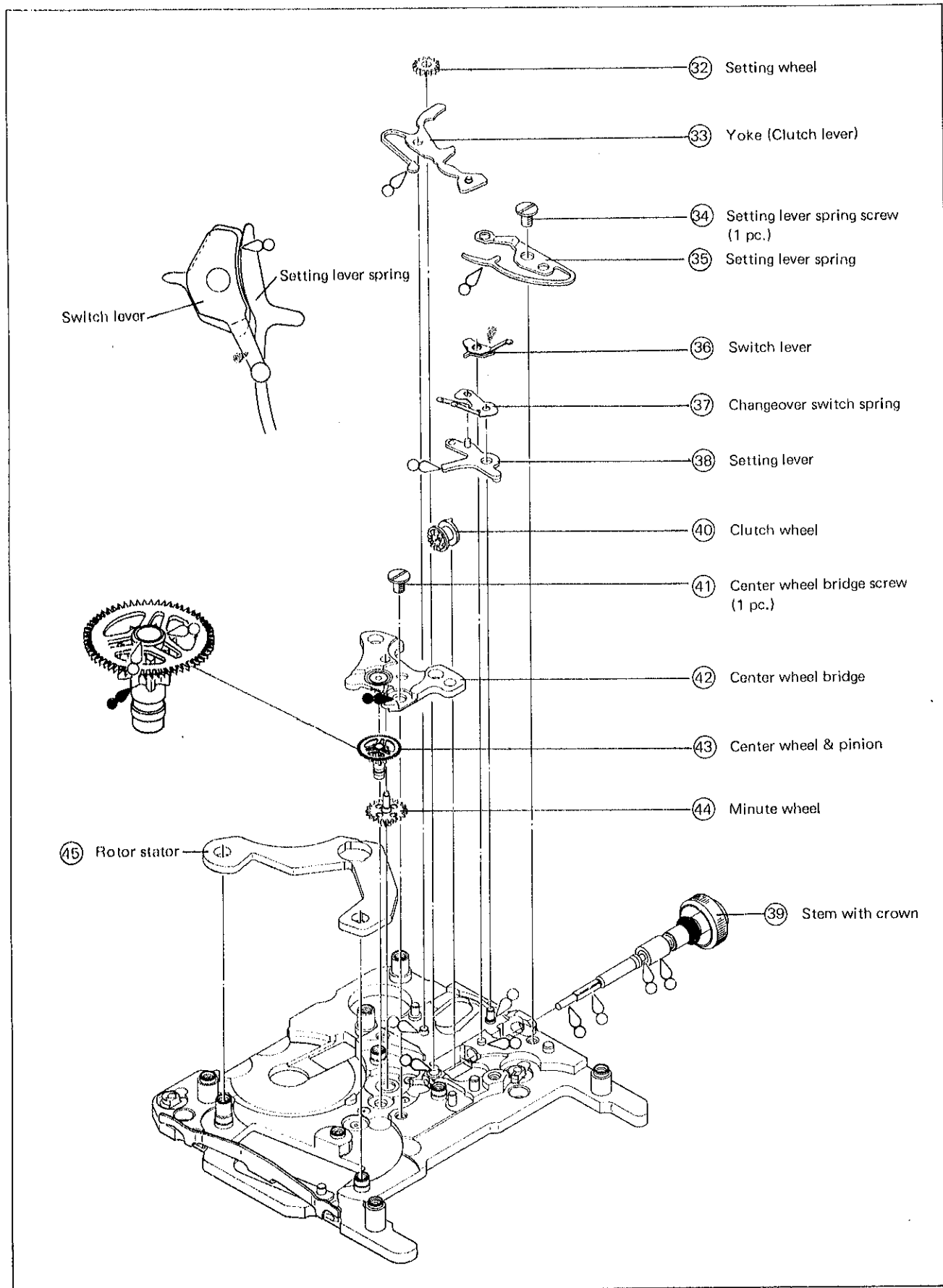

Remarks for disassembling

④② Center wheel bridge

- The axle of the center wheel and pinion is tightened to the center wheel bridge. Be sure to handle the center wheel bridge horizontally when disassembling and reassembling otherwise the parts may be broken.
- Pick it up a little and turn over the main plate and push the center wheel and pinion with tweezers, then it can be untightened.

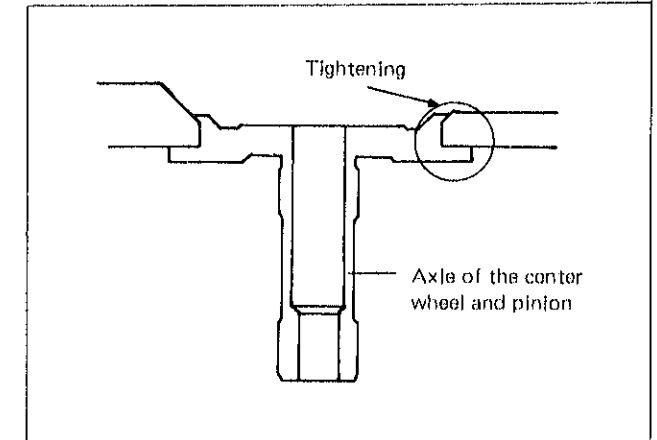

(Structure of the setting mechanism)

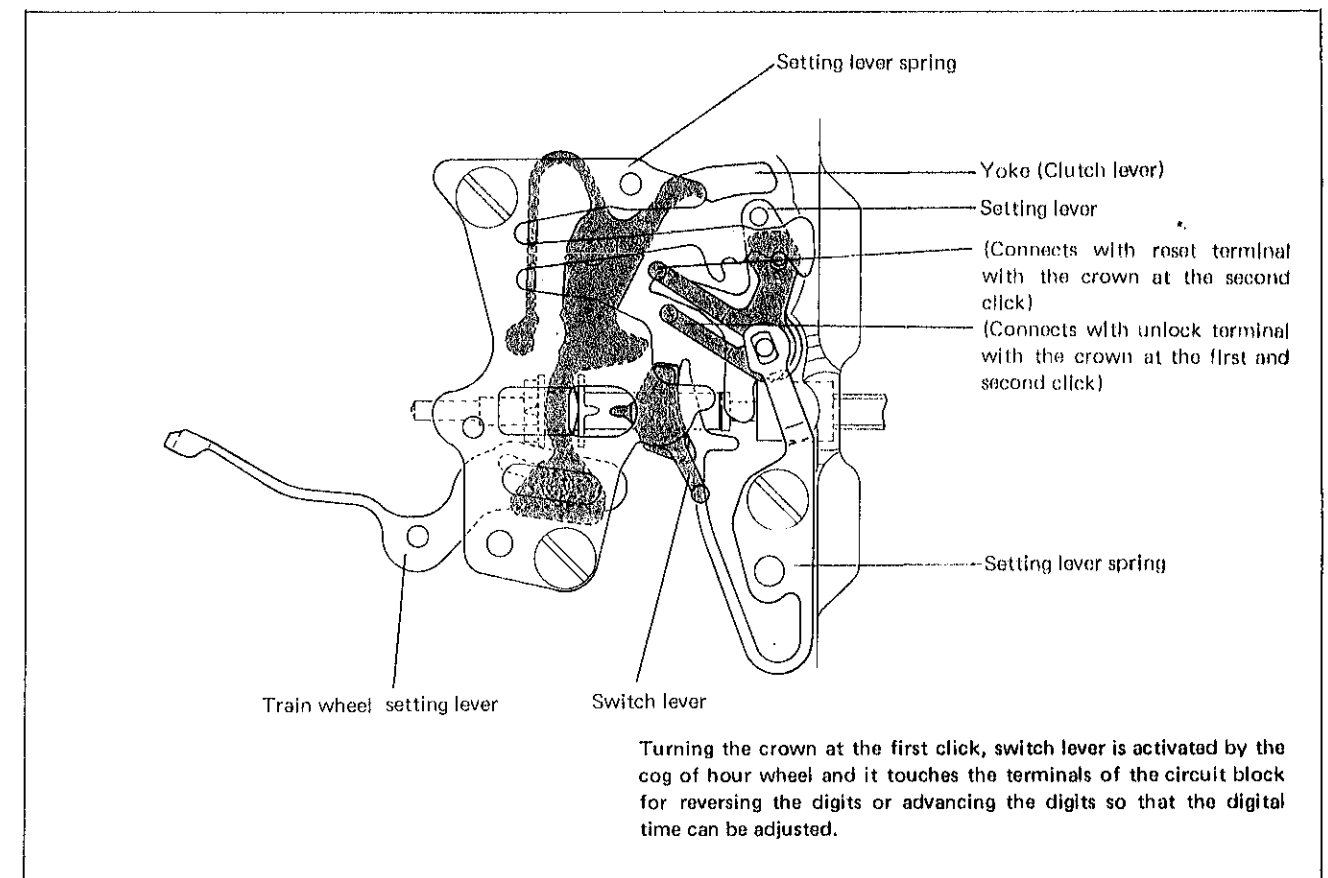

3. Relationship between the segment (Liquid Crystal Panel Electrode) and the C-MOS-LSI output terminal

A complete knowledge of how the segment (Liquid Crystal Panel Electrode) works with the C-MOS-LSI output terminal will provide the proper procedures for checking and adjustment.

• Designation of segments

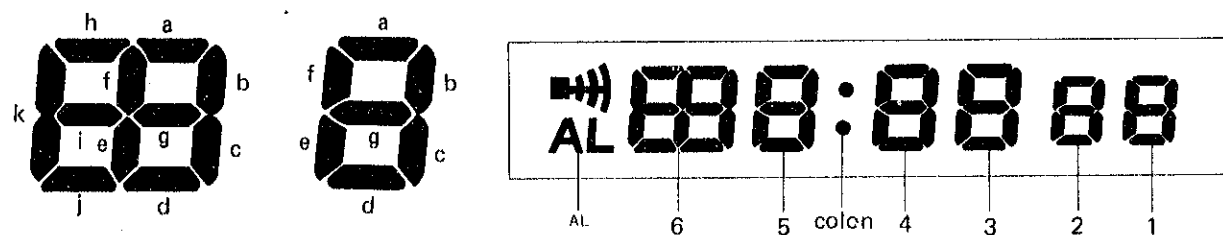

• Relationship between the segment and the C-MOS-LSI output terminal

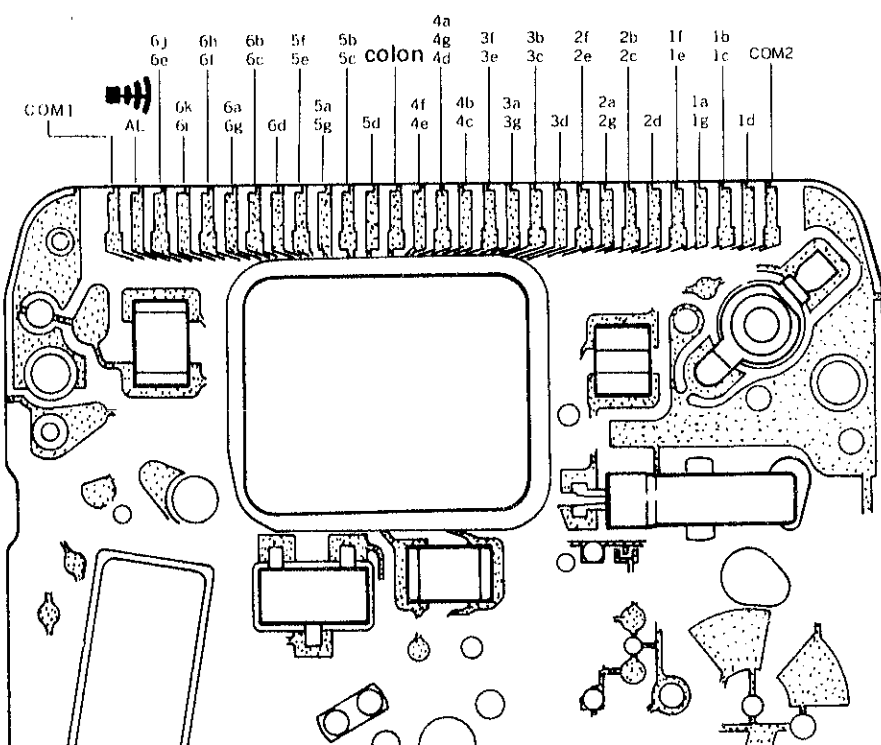
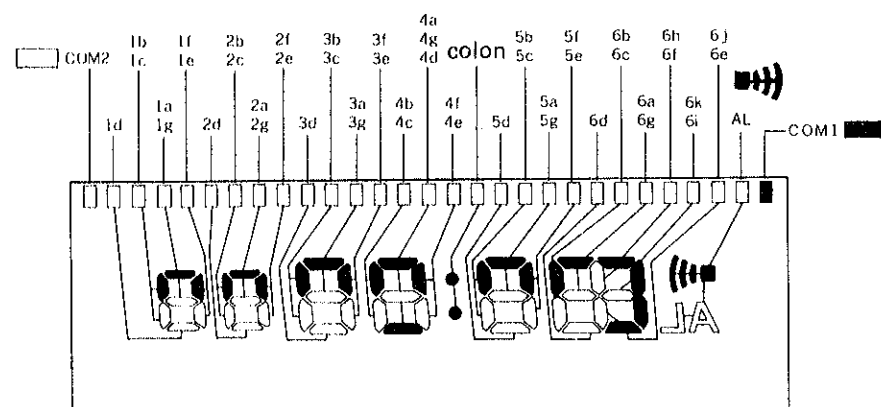

V. CHECKING AND ADJUSTMENT

Refer to the "SEIKO QUARTZ TECHNICAL GUIDE, GENERAL INSTRUCTION for Digital Quartz Watches" and "Analogue Quartz Watches".

| Procedures | |
|---|--|
| CHECK BATTERY VOLTAGE | <p>Result:</p> <p>More than 1.5V: Normal Less than 1.5V: Defective</p> |
| CHECK BATTERY CONDUCTIVITY | |
| CHECK CURRENT CONSUMPTION | |
| <p>1. Current consumption for the whole of the module</p> <p style="text-align: center;">Make sure that the screw is tightened firmly.</p> | <p>Result:</p> <p>Less than 2.5μA: Normal More than 2.5μA: Defective Check current consumption of the circuit block alone.</p> |
| <p>2. Current consumption of the circuit block alone</p> | <p>Result:</p> <p>Less than 1.5μA: Normal Check the coil block and if there is not a short circuit, replace the liquid crystal panel with a new one. More than 1.5μA: Defective Replace the circuit block with a new one.</p> |

Procedures

CHECK WATER RESISTANCE

CHECK PATTERN SEGMENT CHECKING SYSTEM

Pull out the crown with depressing button A.

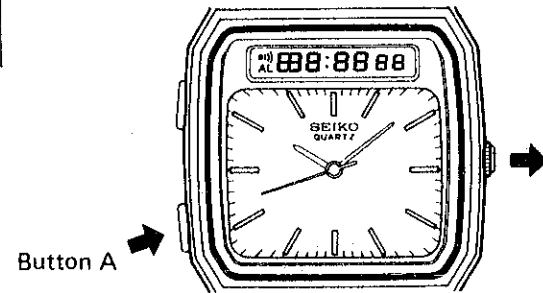

CHECK CONTACT BETWEEN C-MOS-LSI AND LIQUID CRYSTAL PANEL

CHECK LIQUID CRYSTAL PANEL AND CIRCUIT BLOCK

• How to check the circuit block output voltage.

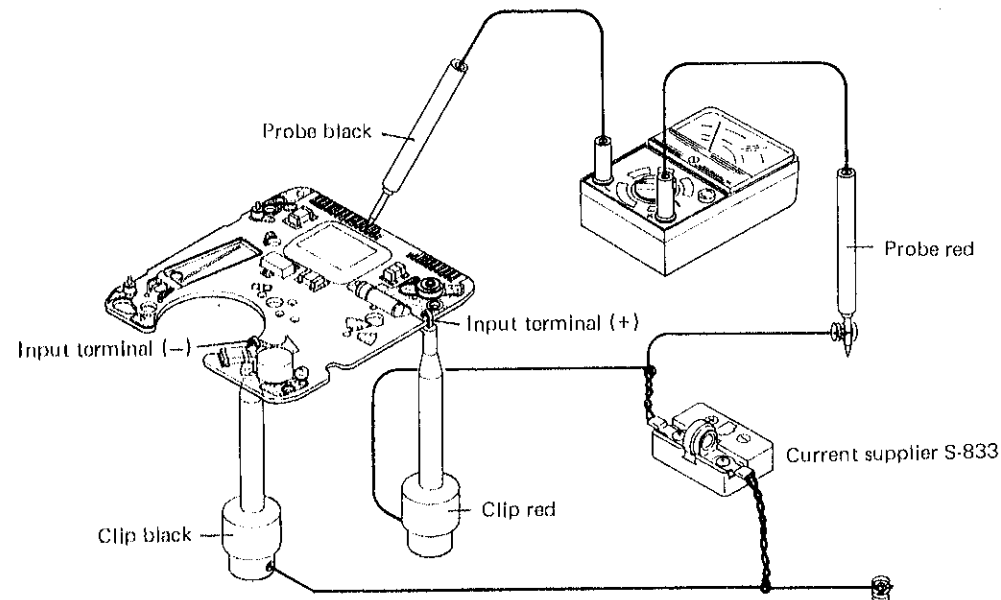

CHECK ACCURACY

- Either electro-magnetic microphone (for analogue watches) or electric-field detection microphone (for digital watches) is available.
- When measuring up with electric-field detection microphone, it is easier to measure the daily rate if all the segments are displayed.

CHECK FUNCTIONING AND ADJUSTMENT

Procedures

CHECK ALARM TEST SYSTEM

Depress button A more than two seconds.

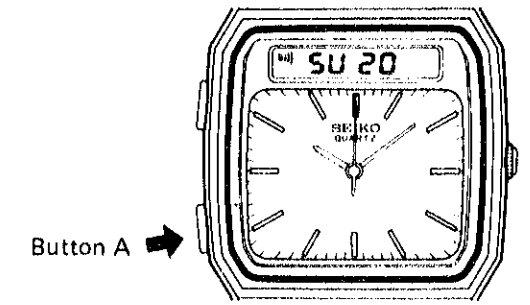

CHECK CONDUCTIVITY OF SWITCH COMPONENTS

CHECK ALARM CONDITION

- How to check upconverter coil
Measure the resistance of the upconverter coil and check if there is a broken wire or a short circuit.
The range to be used for volt-ohm-meter: R x 1

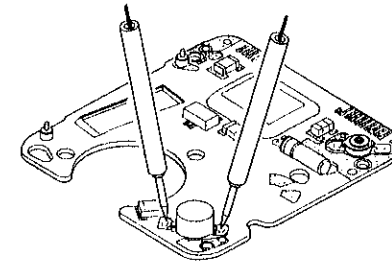

Result:

20Ω ~ 80Ω: Normal
Less than 20Ω (Short circuit)
or over 80Ω (Broken coil wire):
Defective

- Check output signal
Check to see if the output voltage of the alarm function flows from the circuit block correctly.
The range to be used for volt-ohm-meter: DC3V

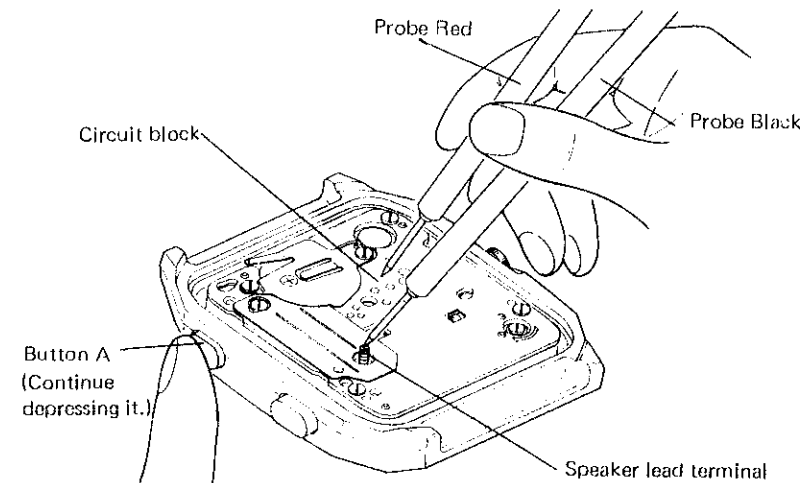

Result:

The pointer swings regularly: Normal
The pointer does not swing: Defective

Note: Be sure to depress button A with the probes applying to them. (That prevents the transistor for buzzer from breaking.)

Procedures

CHECK OUTPUT SIGNAL

Result:

One-second blinking: Normal
 One-second does not blinking:
 Defective

CHECK HAND CONDITION

CHECK CONDUCTIVITY OF CIRCUIT BLOCK

CHECK COIL BLOCK

Result:

$30k\Omega \sim 50k\Omega$: Normal
 Less than $3.0k\Omega$ (Short circuit)
 or over $5.0k\Omega$ (Broken wire):
 Defective

CHECK RESET CONDITION

1. Check to see if the second hand stops immediately when the crown is pulled out to the second click and starts again one second after it is pushed in to the normal position.
2. Disassemble the circuit block and check the height of the tip of changeover switch spring as shown in the illustration.

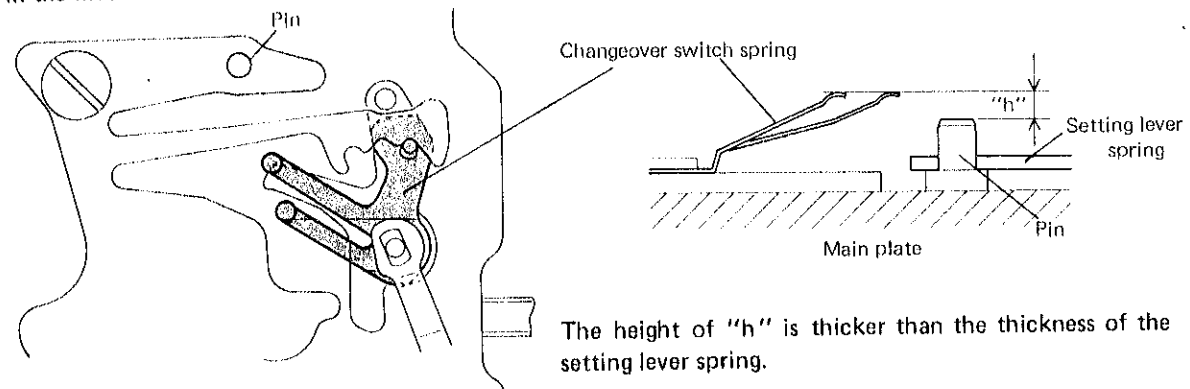

3. Check for the clearance of the train wheel setting lever and fifth wheel and pinion.

The crown at the first click or second click position

The crown at the third click position

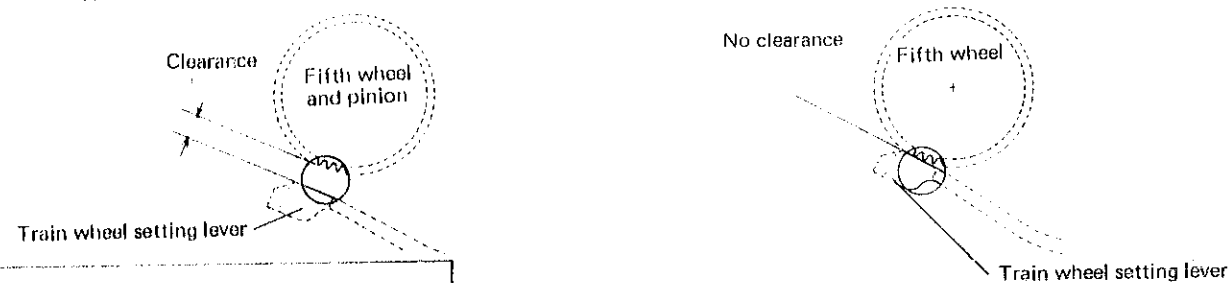

CHECK GEAR TRAIN MECHANISM

All procedures of Disassembling, Reassembling and Adjustment are completed.